

P2

HIGH SPEED AUTOMATIC PRESSES

534 - 1,780 kN

60 - 200 US Tons Capacity



PRODUCT OVERVIEW

Every operation involved in the building of a Minster P2 press, from pouring of castings to final inspection, is based upon the determination to build the finest precision press. Because of this tradition, a Minster P2 gives superior performance, greater accuracy, higher production and longer die life, even under the most severe operating conditions.



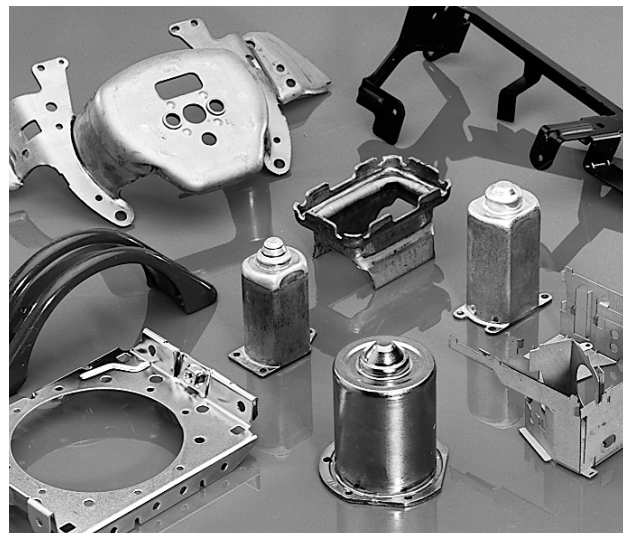
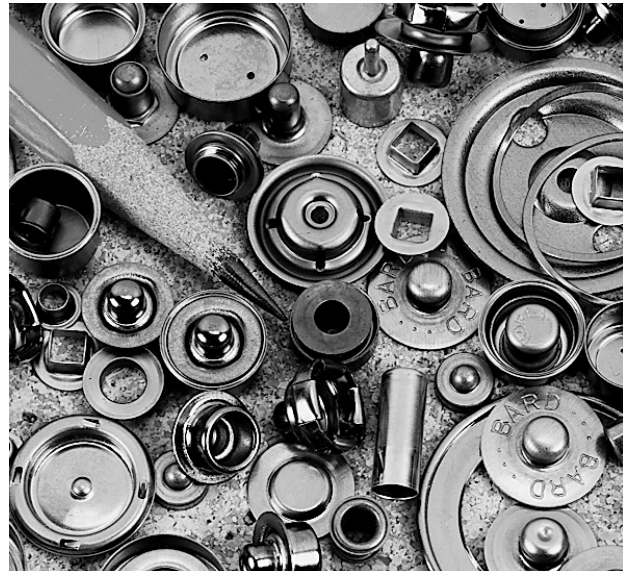
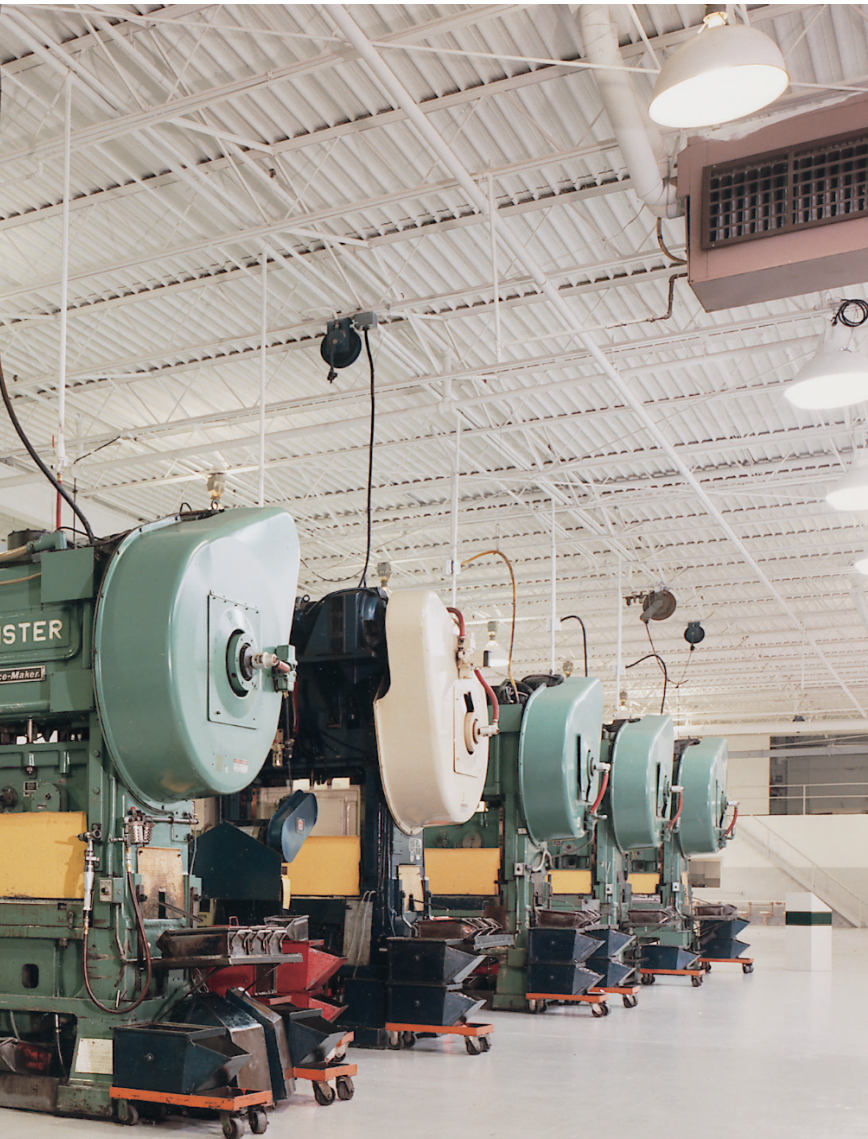

1 Parallelism between bolster and slide face is checked to determine that the precision alignment required on P2 presses has been maintained throughout all stages of construction.

2 Vertical angularity of the slide throughout its entire stroke is checked left to right and front to back. This kind of built-in quality is responsible for precision die alignment necessary for successful progressive die stamping.

STANDARD FEATURES

Cast Construction Reduces Vibration

Minster P2 Series automatic production presses are of high tensile cast iron construction. Parts are properly proportioned for greatest strength without internal stresses. Various alloys are used for different cast parts depending upon their function.

Minster's cast construction is highly efficient in providing the compressive strength and vibration dampening requirements so essential in building a precision press for progressive die work -- particularly on heavy blanking jobs having high fracture loads. You get less punch wear, better die life and more part accuracy because the vibration is held to a minimum in a Minster Piece-Maker.

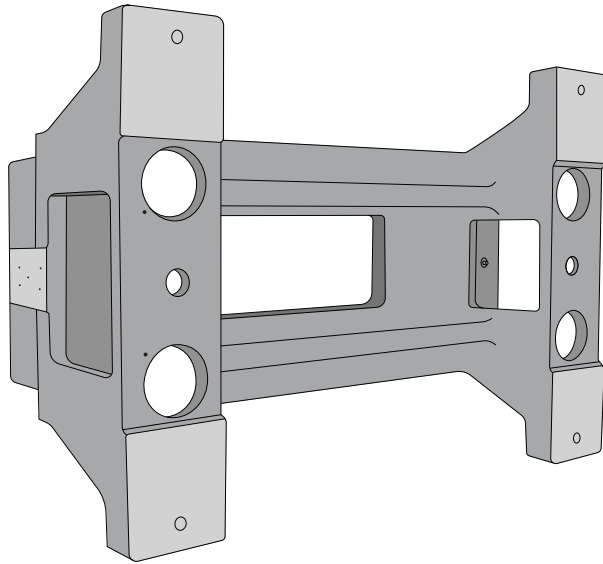

Massive Bed Has Exceptional Rigidity

The superior design and quality construction of the P2 bed gives it the lowest possible deflection characteristics under constant impact and heavy load conditions to maximize tool life and part quality. Oil troughs help contain die lubricants for recycling.

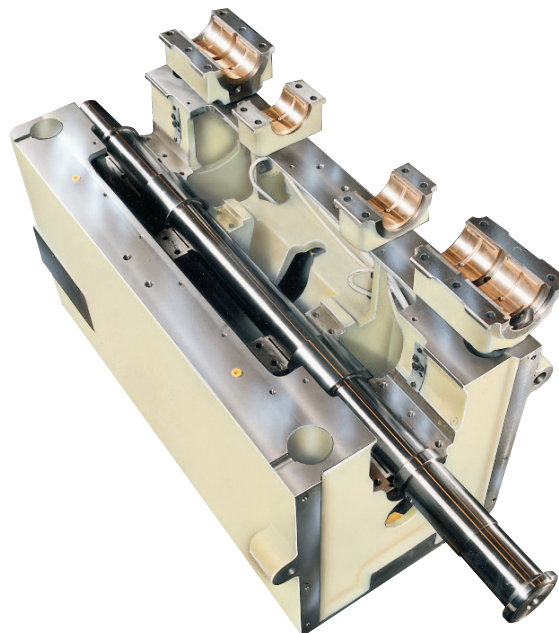

Crown and Eccentric Shaft Provide Strength and Resist Deflection

The massive crown of the Minster P2 is engineered to maximize die life and part quality. Deep crown design backs up the eccentric shaft at any angle against forces created by the stamping application. Close-coupled load carrying plates evenly distribute these forces into the crown structure. The forged steel eccentric shaft resists torsional and bending deflection to enhance die parallelism. It is machined to a superb finish for excellent bearing fits and reduced stresses.

The eccentric shaft eliminates the unsupported areas between main and connection bearings caused by the cheek thickness of the normal crankshaft. The P2 comes standard with one extension. The main bearings of the P2 press give exceptional support to the eccentric shaft. Bearings are line bored for precise alignment. Crankshaft counterweights are standard on all flywheel drive the P2.

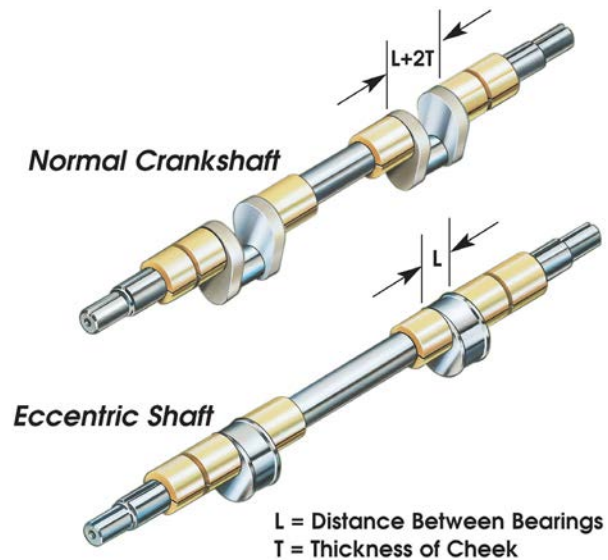

Main Bearing Support Block

This wedge-type support block is precision fitted between the main bearing caps and the top of the uprights. These supports help relieve the stresses placed on bearing cap screws by snap-thru forces and add to die life by stabilizing punch penetration.

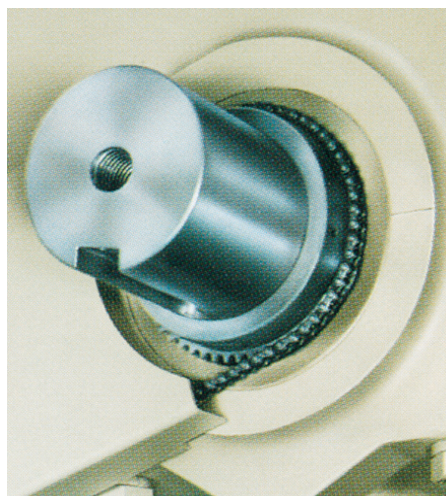

STANDARD FEATURES

Tie Rods Aid Rigidity

Four-piece tie rod construction is used in all Minster P2 frames. Massive steel tie rods are pre-stressed to solidly hold the frame against off-center loading from progressive dies.

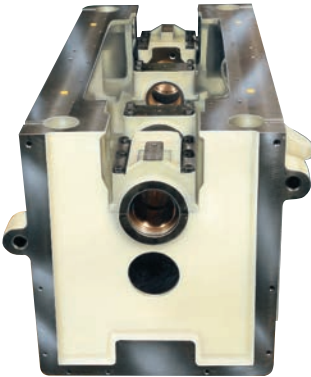

Heavy Slide and Connections

The P2 slide is of deep, heavily reinforced box-type construction, designed to withstand deflection to promote part quality and provide a large die area within the gibs. The massive upper connections easily transmit pressure through the working stroke. Lower connections have removable bronze saddle bushings. All P2 slides are arranged for one cross bar knockout as standard.

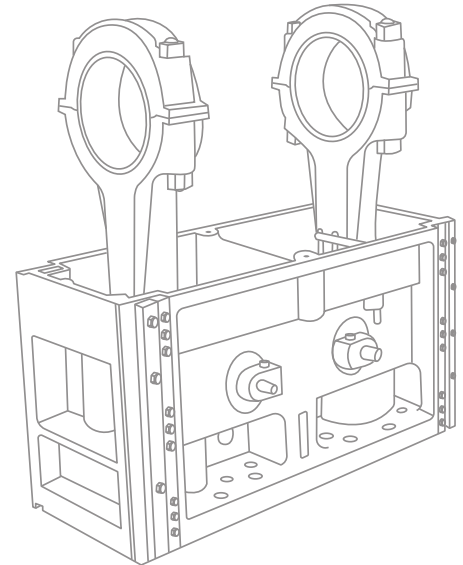

Shutheight Adjustment & Indication

Included as standard is an electronic encoder mounted on the slide that sends a digital readout to the PMC display. This feature aids the operator in accurate die setting procedures. The P2 offers powered slide adjustment for operator ease.

	P2-60		P2-100		P2-150		P2-200	
SLIDE ADJUSTMENT METHOD	Flywheel	Flywheel	Geared	Flywheel	Geared	Flywheel	Geared	
Arranged for Detachable Air Wrench	STD.	STD.	STD.	Option	Option	Option	Option	
Built-In ELECTRIC Motorized	n/a	Option	Option	STD.	STD.	STD.	STD.	
Double Lock-Up w/Manual Adjustment	Option	Option	n/a	Option	n/a	Option	n/a	

8-Point Gibbing for Precision Slide Guiding

Precision slide guiding is maintained by the close-tolerance 8-point gibbing arrangement. Front and rear gibs are accurately squared with the press bed and set for proper clearance by spacers under each main gib bolt, thus eliminating trial and error adjustment. Front to back ways have fixed bronze wear plates, machined square with the slide face. Left to right ways are adjusted and supported their full length by tapered back-up bars.

The extra-long gibs guide the slide fully within the gibs throughout the stroke -- even at maximum shutheight adjustments. This assures excellent slide-to-bed parallelism at all times, contributing to clean material fracture, high part accuracy, and increased die life. Slide and bolster are machined with standard T-Slots.

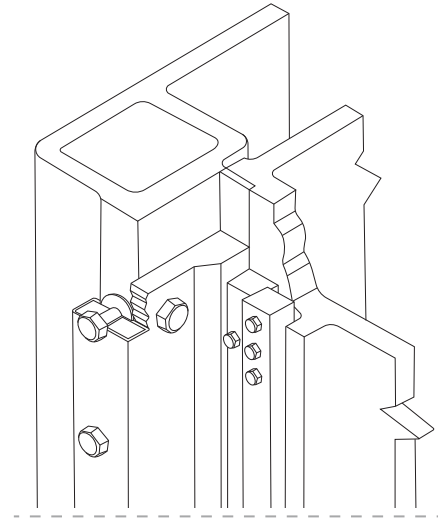

Production Management Control (PMC)

Incorporates all press functions including:

- Full machine diagnostics detailing all press and feed line faults.
- Multiple selectable languages.
- Open architecture which allows for greater convenience in planning and maintenance.
- PLC and color touch screen technology; all press and feed line functions can be monitored for efficient diagnosis of production line faults.

Available popular options include: die protection, load monitoring as well as automatic shutheight and counterbalance controls.

FieldHawk - Industry 4.0

FieldHawk is a cloud-based mobile application designed to communicate with your NP&A stamping press lines from your iOS or Android mobile devices. Cloud-based, secured communications allows all authorized users to check machinery status from anywhere you can get phone service and/or an internet connection, thus reducing downtime.



STANDARD FEATURES

Drive Arrangements for Maximum Press Efficiency

Flywheel type presses run at higher speeds and have shorter strokes for punching, notching, blanking and shallow forming or drawing operations on lighter materials. The Clutch and Brake Unit is mounted on the eccentric shaft within the flywheel. Flywheel rotates on anti-friction bearings. Flywheel brake is electrically interlocked with drive "Stop" circuit to eliminate "coasting."

Single Geared P2 presses incorporate helical gears for quiet operation, heavier material blanking, punching and deeper forming or drawing operations. The Clutch and Brake Unit is mounted on the eccentric shaft within the main drive gear which rotates on anti-friction bearings. This arrangement provides a wider than normal speed range for a geared press. All Minster P2 presses use a variable frequency drive motor for long life and easy operator adjustment.

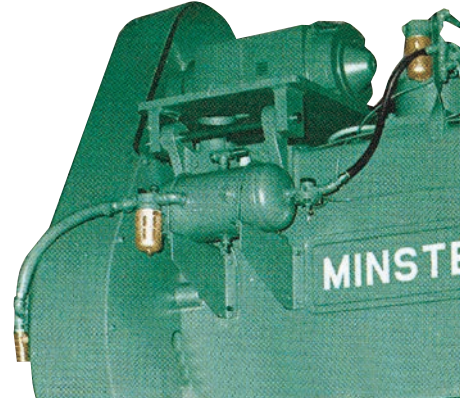

Flywheel Drive



Geared Drive Motor is on rear as shown.

Minster MonitorFlow Continuous, Monitored Press Lubrication

The patented Minster MonitorFlow Pressurized Recirculating Oil Lubrication System supplies a continuous flow of filtered oil under pressure to all bearing surfaces ensuring reliable operation. It monitors both the flow to these points as well as oil level and pressure in the entire system. If a fault occurs, it protects the bearings by stopping the press operation before damage happens. From the manifold in the press crown, oil is channeled to bearings, gibs, gears, and counterbalances. Flow switches monitor oil flow to main and connection bearings and through sump line to reservoir. This protects against either broken or plugged lines.

In the event of a lubrication fault, the Global Message Screen within the control instantly indicates which flow switch (or switches) signaled the fault, helping to pinpoint the problem area.

Minster Combination Air Friction Clutch and Brake Increases Die Life and Parts Production

This Single Unit, Automatically Synchronized, combination, multiple disc clutch and brake has one moving member engaging the clutch by air pressure or applying the brake by spring pressure. Movement from full brake to complete engagement is approximately 1/16" assuring quick, controlled stopping at any speed. Engagement on 360° friction surfaces remains constant throughout the stroke eliminating backlash after stamping and on the upstroke. Clutch Bumping Arrangement and Power Off Flywheel Barring are standard on flywheel type presses 100 tons and smaller.

Mechanical Options

- Bolster machining and precision T-slots
- Crossbar knockout parts
- Detachable air slide adjustment wrench
- Press mounts
- Die cushions
- Die safety block
- Special paint

SPECIFICATIONS & DIMENSIONS

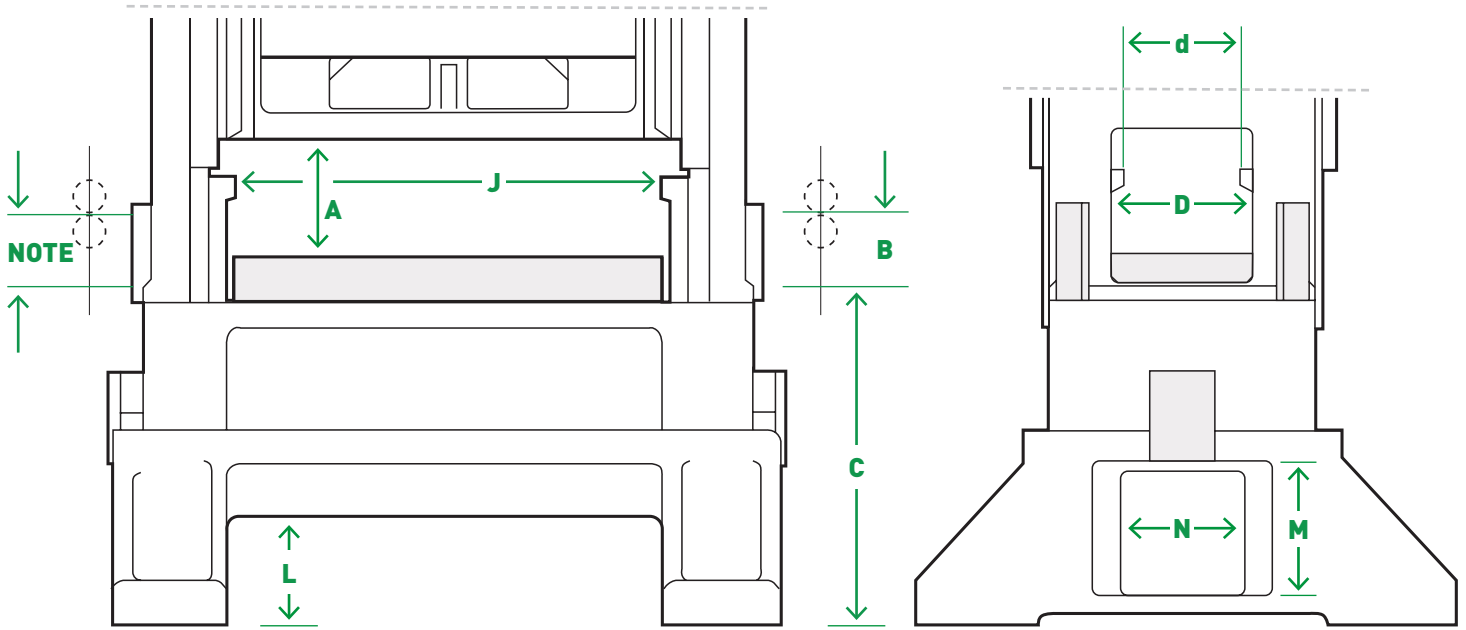

NOTE: Specify maximum and minimum feed line height from bed.

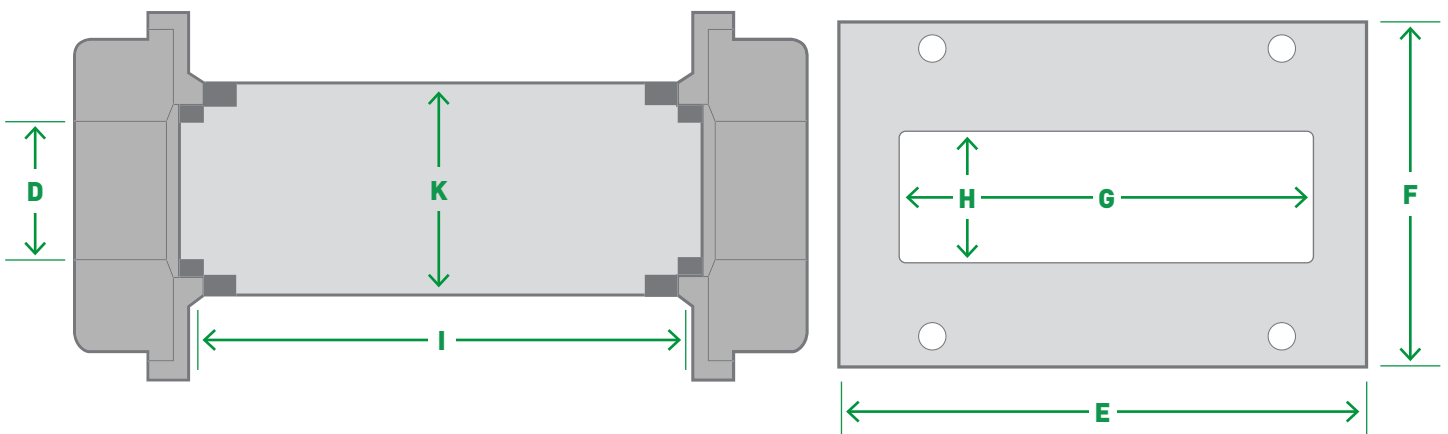

	P2-60		P2-100		P2-150		P2-200	
Dimensions Common to all Widths	Flywheel Type	Flywheel Type	Single Geared	Flywheel Type	Single Geared	Flywheel Type	Single Geared	
Tons Capacity at Bottom of Stroke	550 kN		910 kN		1350 kN		1800 kN	
Crankshaft Dia. @ Bearings/Min. Dia. of Eccentrics	100/145		125/170		165/235		180/235	
Crankshaft Extension (Standard): Length/Diameter	165/85		255/100		255/125		225/125	
Crankshaft Extension (Standard): Keyway Size	20 x 10		20 x 10		30 x 15		30 x 15	
Adjustment of Slide: Standard Locking Arrangement	75		100		100		150	
A Shutheight on Bolster, S.D.A.U. (Standard Stroke 25 mm)	320		370		470		495	
A Shutheight on Bolster, S.D.A.U. (Standard Stroke 50 mm)	305		405		455		480	
A Shutheight on Bolster, S.D.A.U. (Standard Stroke 75 mm)	290		395		420		445	
A Shutheight on Bolster, S.D.A.U. (Standard Stroke 100 mm)	280		380		405		475	
A Shutheight on Bolster, S.D.A.U. (Standard Stroke 125 mm)			355		375		445	
A Shutheight on Bolster, S.D.A.U. (Standard Stroke 150 mm)			380		430		480	
A Shutheight on Bolster, S.D.A.U. (Standard Stroke 175 mm)							420	
A Shutheight on Bolster, S.D.A.U. (Standard Stroke 200 mm)							405	
B Thickness of Bolster Plate	90		125		150		175	
C Distance Floor to Top of Bed	865		915		1065		1065	
d/D Opening in Upright (Absolute Maximum) F-B	265/305		355/405		380/455		380/510	
M&N Opening in Leg (Exit Side) T-B x F-B	355 x 315		355 x 355		380 x 455		380 x 510	
Overall Height (Approximate)	2870		3405		3990		4115	
kW and Speed of Variable Speed Motor Drives	11.25/1800		15/1800		18/1200 or 18/1800		22/1200 or 22/1800	
Sliding Die Cushion -- Capacity	23 kN		87 kN		139 kN		139 kN	
Width of Press					1220		1525	
I&K Area of Slide: R-L x F-B					1220 x 585		1525 x 760	
J Distance Between Gibs					1,270		1575	
E&F Area of Bolster and Bed: R-L x F-B					1220 x 1015		1525 x 1115	
G&H Opening in Bed: R-L x F-B					965 x 480		1370 x 445	
L Floor to Bottom of Bed to Clear (Without Mounts)					355		305	
Floor Space Overall: R-L x F-B					2820 x 2335		2715 x 2310	
Weight (kg)					21,150		22,950	
					30,150		32,400	
Width of Press	1220		1220		1525		1830	
I&K Area of Slide: R-L x F-B	1220 x 380		1220 x 470		1525 x 585		1830 x 760	
J Distance Between Gibs	1270		1270		1575		1880	
E&F Area of Bolster and Bed: R-L x F-B	1220 x 635		1220 x 785		1525 x 1015		1830 x 1115	
G&H Opening in Bed: R-L x F-B	1065 x 230		1040 x 380		1270 x 455		1525 x 455	
L Floor to Bottom of Bed to Clear (Without Mounts)	340		305		355		305	
Floor Space Overall: R-L x F-B	2185 x 1370		2665 x 1525		2490 x 1830		3125 x 2335	
Weight (kg)	8,910		12,690		13,770		23,400	
					25,650		30,600	
							32,400	
Width of Press			1525					
I&K Area of Slide: R-L x F-B			1525 x 470					
J Distance Between Gibs			1575					
E&F Area of Bolster and Bed: R-L x F-B			1525 x 470					
G&H Opening in Bed: R-L x F-B			1345 x 380					
L Floor to Bottom of Bed to Clear (Without Mounts)			305					
Floor Space Overall: R-L x F-B			2970 x 1525		2795 x 1830			
Weight (kg)			13,950		14,940			

SPECIFICATIONS & DIMENSIONS

U.S. STANDARD		P2-60		P2-100		P2-150		P2-200	
Dimensions Common to all Widths		Flywheel Type	Flywheel Type	Single Geared	Flywheel Type	Single Geared	Flywheel Type	Single Geared	
	Tons Capacity at Bottom of Stroke (U.S. Tons)	60		100		150		200	
	Crankshaft Dia. @ Bearings/Min. Dia. of Eccentrics	4/5.75		5/6.75		6.5/9.25		7/9.25	
	Crankshaft Extension (Standard): Length/Diameter	6/3.375		10/3.875		10/5.0		10/5.0	
	Crankshaft Extension (Standard): Keyway Size	.75 x .375		.75 x .375		1.25 x .62		1.25 x .62	
	Adjustment of Slide: Standard Locking Arrangement	3.0		4.0		4.0		6.0	
A	Shutheight on Bolster, S.D.A.U. (Standard Stroke 1.0")	12.5		14.5		18.5		19.5	
A	Shutheight on Bolster, S.D.A.U. (Standard Stroke 2.0")	12.0		16.0		18.0		19.0	
A	Shutheight on Bolster, S.D.A.U. (Standard Stroke 3.0")	11.5		15.5		16.5		17.5	
A	Shutheight on Bolster, S.D.A.U. (Standard Stroke 4.0")	11.0		15.0		16.0		18.75	
A	Shutheight on Bolster, S.D.A.U. (Standard Stroke 5.0")			14.0		14.75		17.5	
A	Shutheight on Bolster, S.D.A.U. (Standard Stroke 6.0")			15.0		17.0		19.0	
A	Shutheight on Bolster, S.D.A.U. (Standard Stroke 7.0")							16.5	
A	Shutheight on Bolster, S.D.A.U. (Standard Stroke 8.0")							16.0	
B	Thickness of Bolster Plate	3.5		5.0		6.0		7.0	
C	Distance Floor to Top of Bed	34		36		42		42	
d/D	Opening in Upright (Absolute Maximum) F-B	10.5/12.0		14.5/16.0		19.0/20.0		21.0/22.0	
M&N	Opening in Leg (Exit Side) T-B x F-B	14 x 12.5		14 x 14		15 x 18		15 x 20	
	Overall Height (Approximate)	129		147		163		173	
	HP and Speed of Variable Speed Motor Drives	15/1,800		20/1,800		25/1,200 or 25/1,800		30/1,200 or 30/1,800	
	Sliding Die Cushion -- Capacity	2.5 Tons		9.6 Tons		15.3 Tons		15.3 Tons	
Width of Press						48		60	
I&K	Area of Slide: R-L x F-B					48 x 23		60 x 30	
J	Distance Between Gibs					50		62	
E&F	Area of Bolster and Bed: R-L x F-B					48 x 40		60 x 44	
G&H	Opening in Bed: R-L x F-B					38 x 19		54 x 18	
L	Floor to Bottom of Bed to Clear (Without Mounts)					14		12	
	Floor Space Overall: R-L x F-B					111 x 92		125 x 94	
	Weight (Lbs.)					47,000		51,000	
Width of Press		48		48		60		72	
I&K	Area of Slide: R-L x F-B	48 x 15		48 x 18.5		60 x 23		72 x 30	
J	Distance Between Gibs	50		50		62		74	
E&F	Area of Bolster and Bed: R-L x F-B	48 x 25		48 x 31		60 x 40		72 x 44	
G&H	Opening in Bed: R-L x F-B	42 x 9		41 x 15		50 x 19		60 x 18	
L	Floor to Bottom of Bed to Clear (Without Mounts)	13.5		12		14		12	
	Floor Space Overall: R-L x F-B	86 x 54		105 x 60		123 x 92		119 x 91	
	Weight (Lbs.)	19,800		28,200		30,600		52,000	
Width of Press				60					
I&K	Area of Slide: R-L x F-B			60 x 18.5					
J	Distance Between Gibs			62					
E&F	Area of Bolster and Bed: R-L x F-B			60 x 31					
G&H	Opening in Bed: R-L x F-B			53 x 15					
L	Floor to Bottom of Bed to Clear (Without Mounts)			12					
	Floor Space Overall: R-L x F-B			117 x 60		110 x 72			
	Weight (Lbs.)			31,000		33,200			

SPEED / STROKE COMBINATIONS

Stroke	P2-60 FLYWHEEL		P2-100 FLYWHEEL		P2-150 FLYWHEEL		P2-200 FLYWHEEL		P2-100 GEARED		P2-150 GEARED		P2-200 GEARED	
	Std. Speed	Max. Speed	Std. Speed	Max. Speed	Std. Speed	Max. Speed	Std. Speed	Max. Speed	Std. Speed	Max. Speed	Std. Speed	Max. Speed	Std. Speed	Max. Speed
1.0" (25 mm)	450	600	350	500	300	450	300	400						
1.5" (38 mm)	400	500	300	450	300	400	300	350						
2.0" (50 mm)	375	400	300	400	250	350	250	300						
2.5" (64 mm)	350	375	250	350	220	300	220	275						
3.0" (75 mm)	300	350	250	300	200*	250	200*	250						
4.0" (100 mm)	200	300	160	250	150*	225	150*	225	120	150	120	150	120	150
5.0" (125 mm)			160	200	150*	200*	150*	200*	100	150	100	150	100	150
6.0" (150 mm)							150*	180*	90	120	90	120	90	120
7.0" (175 mm)													90	120
8.0" (205 mm)													90	120

STANDARD



*Requires 1200 RPM Drive Motor



One Brand: A World of Resources

Nidec Press & Automation is the full service pressroom provider of choice for businesses in more than 90 countries and on six continents. Comprised of leading press room product brands, we ensure a complete offering of machinery, services and technology to meet your exact needs, enabling you to rely on one source.

Discover the freedom to achieve, to maximize and to drive your operation to exceed your goals. At Nidec Press & Automation, your success is the core of our focus and how we design our solutions to meet the rigid needs of the metal forming industry.

Choosing to work with us means you gain a constant resource with a global footprint, the brightest minds behind our solutions, and backed by regionally based OEM support ready to work as a natural extension of your team.

**Our promise to you is simple:
We're with you whenever and wherever
business takes you.**



MACHINERY

- Turn Key Systems
- Individual Components
- System/Tech Upgrades
- Industry 4.0 Software Upgrades
- Integrated Controls

METAL FORMING PRESS APPLICATIONS

- Mechanical
- Servo
- Transfer
- High-Speed & Electrical
- Electrical Vehicle (EV)
- Lamination
- Container Cupping
- Container End-Conversion
- Container Shell
- Gap/D-Frame

AUTOMATION

- Press Tending / Robotics
- Integrated Transfers
- High Speed Servo Feeds
- High Speed Gripper Feeds
- Heavy-Duty Coil Lines

GLOBAL SERVICE NETWORK

- Field Service
- Remanufacturing
- Spare Parts
- Technical Service
- Training
- Planned Maintenance
- Inspection & Audit
- Relocation
- Upgrade Services
- Engineering Services

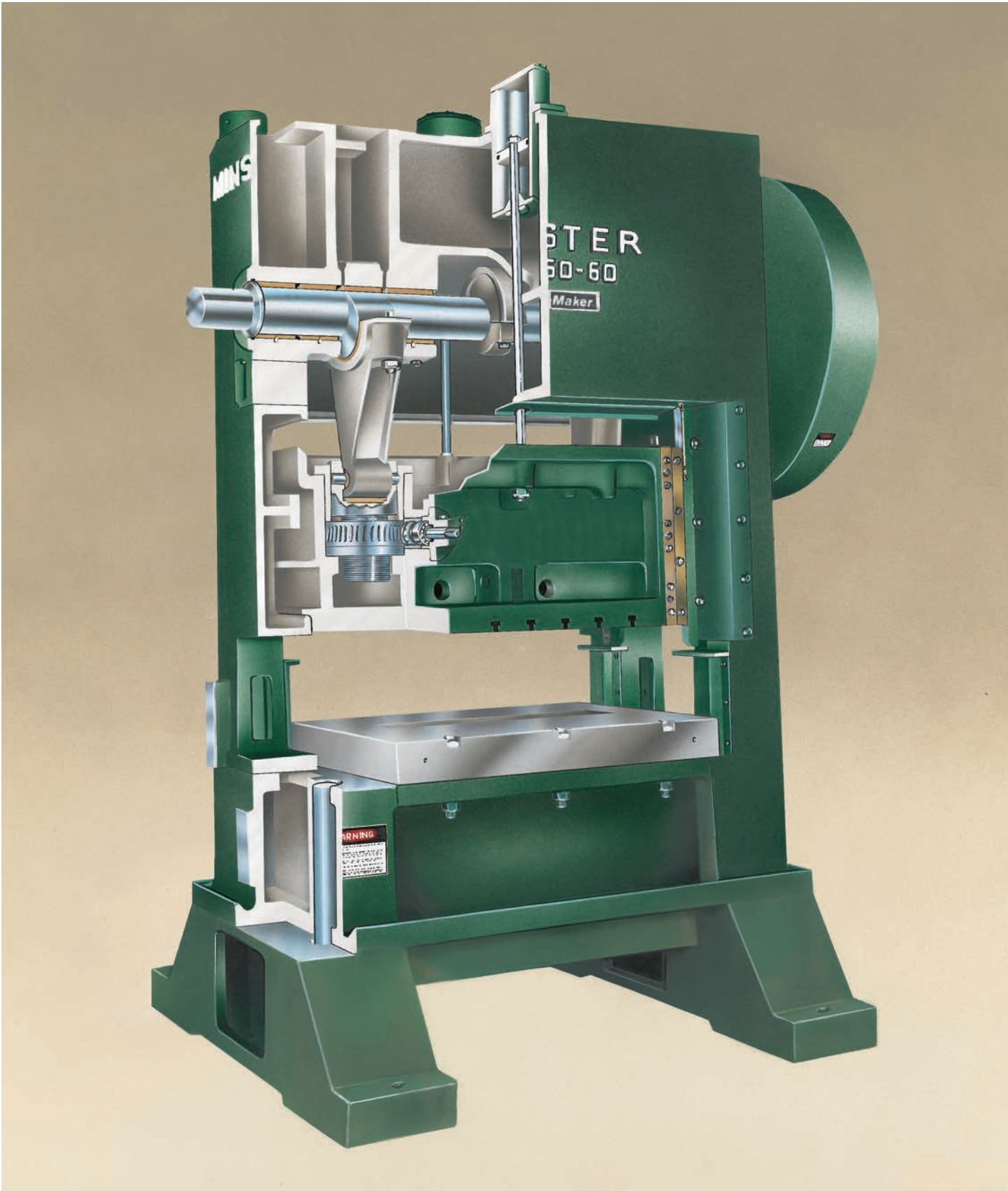



One Brand: A World of Resources

A single source solution that will help you find the efficiencies you want — all from the products, services and technology of Nidec Press & Automation.

nidecpa.com