

**VX**

## VARIABLE STROKE HIGH PERFORMANCE PRESSES

356 - 712 kN  
40-80 Tons Capacity



## PRODUCT OVERVIEW

With more than 40 years of expertise in link motion press technology, Kyori's knuckle link presses have earned the reputation for high precision, high performance and ease of operation from users all around the world.



- 1** Optimal flexibility to run dies of various heights because of adjustability of variable stroke mechanism.
- 2** Low maintenance costs from the rugged and proven design of more than 4,000 presses installed.



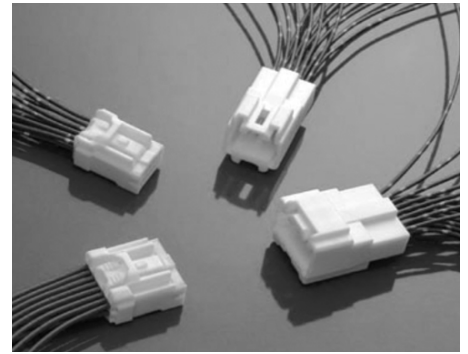
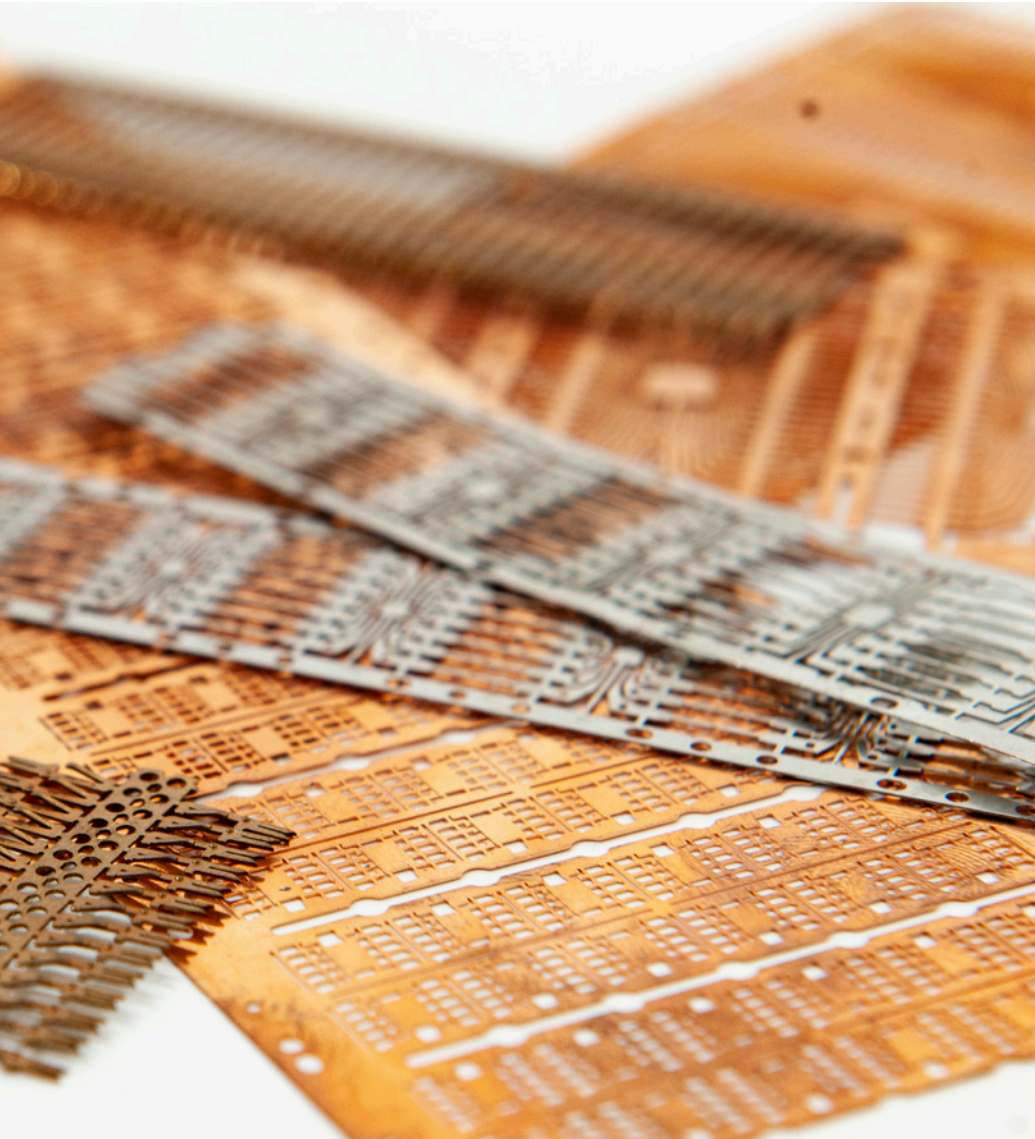

**3** Ease of tool set-up and storage from integrated press and feed controls with the Vamco SR series feeds.

**4** Increased tool life and part quality from knuckle link motion creating a slower slide movement through bottom dead center.

**5** The die height stays the same no matter the stroke length, allowing faster die change times and feed setup.

**6** No need for thermal or dynamic stroke length compensation mechanisms creating less complicated drive mechanism.

## STANDARD FEATURES

### Symmetrical Link Design

The knuckle link design of the VX series presses eliminates thermal displacement resulting in precise bottom-dead-center repeatability. In addition, the design contributes to greater durability, longer die life and reduced noise and vibration.

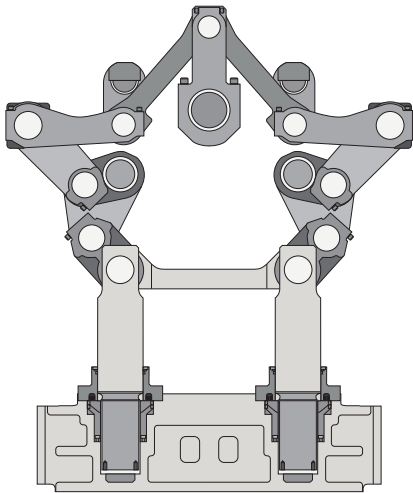

### Accurate Slide Guiding

Kyori VX presses use 8-point needle bearings for slide guiding as opposed to competitors' post guiding systems. Needle bearings are able to withstand a much larger load and the long guide ways resist off-center loading. The positioning of the guides make them easy to maintain.

### The Link Slide Motion

The link slide motion allows for more time on the bottom of the stroke for better part forming and reduced impact of snap-thru forces which extends press and die life. The time between re-sharpening of the dies in a VX series press is more than 25% greater than that of a conventional crank press.

### Slide Motion

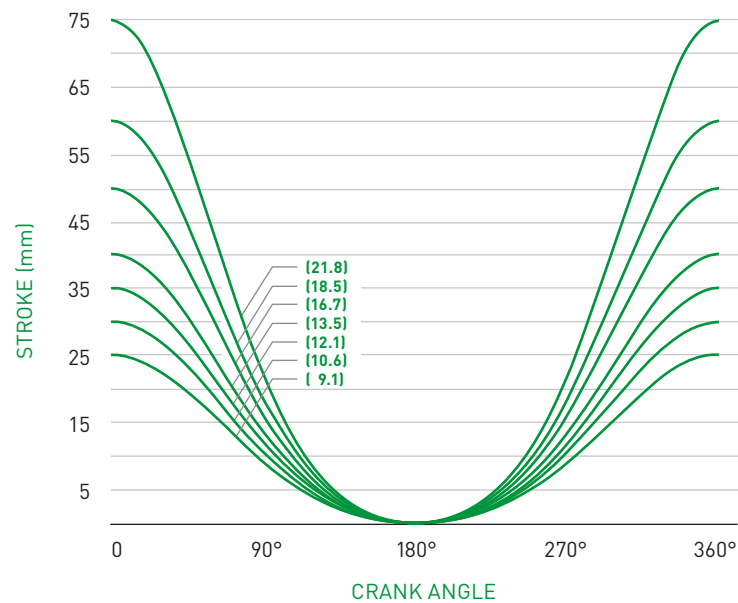

### Eight-Point Needle Bearings

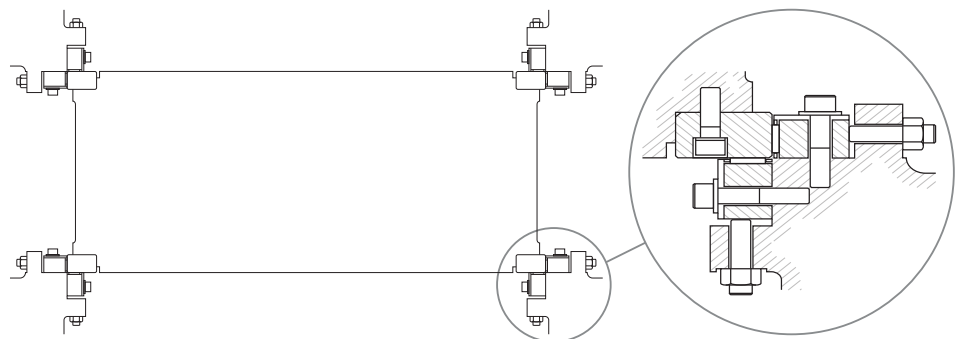

### Dynamic Balancer

The dynamic balancer feature allows the press to be operated at full speed with minimal inertial effect. The balancer weight reciprocates as the slide moves downward resulting in perfect balance vertically and horizontally with minimal vibration.

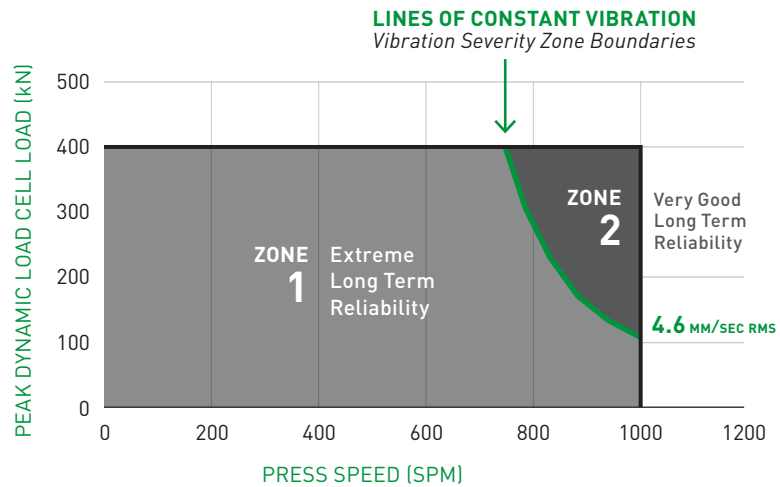

### Minimal Shutheight Variation

The VX link mechanism is constructed with greater mass than a conventional crank mechanism contributing to greater rigidity and strength. This combination of dynamic balancer and greater mass results in minimal dynamic displacement and shutheight variation producing greater bottom dead center repeatability.

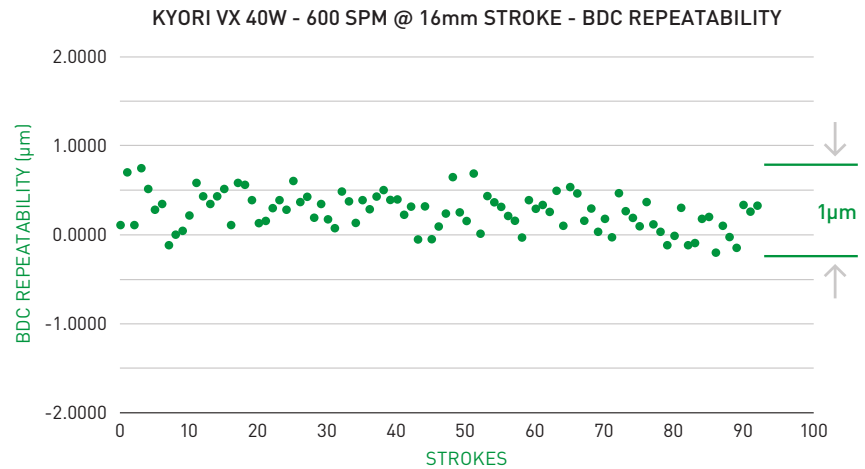

### Heat Generation and Thermal Cancellation

The design of the VX link mechanism allows for smaller bearings, thus producing less heat without sacrificing rigidity or causing overheating of the bearings. As the links heat up, one causes the shutheight to open while the other causes it to close, canceling the thermal displacement. The result is greater accuracy and bottom dead center repeatability.

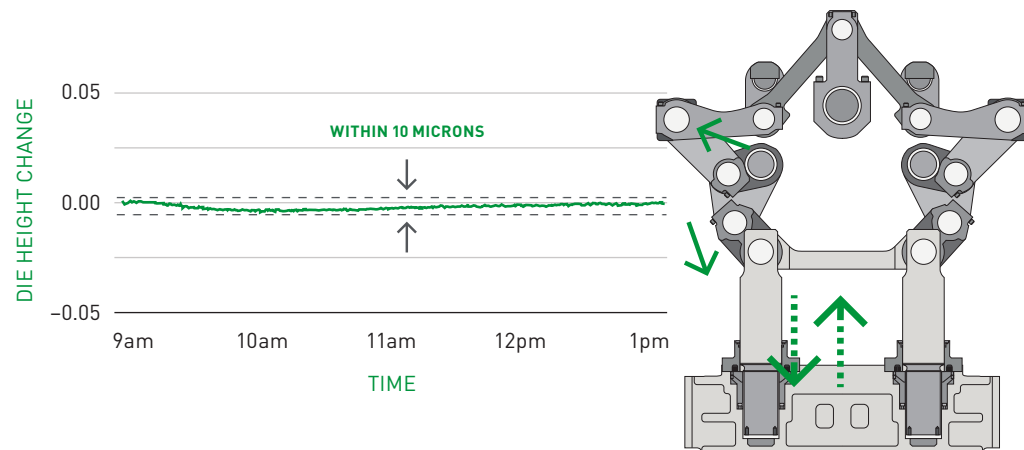

## STANDARD FEATURES

### 40 Grade Cast Iron Frame Construction

This construction provides the compressive strength and vibration dampening characteristics that provide greater die life and part accuracy. Iron has 2.5 to 4.5 times the dampening capability of steel. Therefore, the VX utilizes castings where applicable in its beds, crowns and uprights to dampen vibration and noise created in high vibration and snap-thru applications.

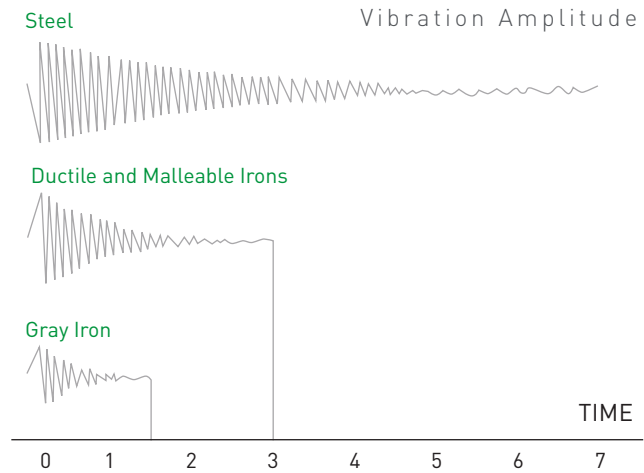

### Combination Air Friction Clutch and Brake Unit

One moving member engages the clutch by air pressure or applies the brake by spring pressure. Movement from full brake to complete engagement is approximately 1.59 mm assuring quick, controlled stopping at any speed increasing die life and parts production. Engagement on 360° friction surfaces remains constant throughout the stroke eliminating backlash after stamping and on the upstroke.



### Motorized Slide Adjustment

The slide adjustment on the VX press is driven by a servo motor and the exact shutheight is displayed on the press console and the repeatability is within 0.01 mm.

### Oil Heater/Chiller

To ensure accurate bottom-dead-center repeatability, the unit can be programmed to heat and circulate the oil prior to operation. Once the press is in production mode, the oil is circulated through the chiller to maintain the proper temperature. The temperature is achieved automatically by the press SPM.

### Continuous Press Lubrication

The VX incorporates a pressurized recirculating oil lubrication system which supplies a continuous flow of filtered oil under pressure to all bearing surfaces ensuring reliable operation.

---

### **Main Motor**

The inverter-type main drive motor on the VX series of presses is variable speed drive providing greater flexibility and higher performance throughout the full speed range, resulting in lower cost to the user.

---

### **Electronic Stroke Position Indicator**

Brightly lit and easily seen, the stroke position indicator displays the exact crank angle.

---

### **Die Doors**

These standard safety features include pneumatically controlled doors with up and down motion on the front of the press and/or cabinet style doors on the rear of the VX-40 and up and down motion both front and rear on the VX-50 and VX-80.

---

### **Micro Inching**

Kyori VX users can enjoy the feature of micro-inching of the press to assist with die set-up and troubleshooting.

---

### **Shock Mounts**

Isolation/leveling mounts are included as standard equipment on Kyori VX series presses.

---

### **Additional Standard Features**

- Two-hand push button
- Pneumatic control unit
- Stock guide
- End of stock detector
- Air outlet

## OPTIONAL FEATURES

### Optional Features

- Die Height Detector (4-Channel)
- Cutting Counter (100V / 24V Outlet)
- Air Ejector With DC Solenoid Valve
- Die consoles
- Die Clamps (Upper & Lower)
- Die Lift Rails (2 Front, 2 Rear)
- Motor Reverse Device
- Flywheel brake
- Programmable I/O
- Utility receptacles
- Manual barring (*Only applicable to VX-40*)

### Optional Vamco SR Feed Integration

Designed to consistently perform and withstand the vibration of the most severe stamping applications, the SR series is directly mounted to the press and is electronically cammed to the crankshaft ensuring the highest feeding performance.

- Double axis servo feed (feed rolls & pilot release)
- Electronic camming
- Fully-programmable feed & release settings
- Powered upper & lower feed rolls
- Durable cast frame construction
- Advanced monitoring diagnostics
- Push/pull configurations and DHS (3-axis) versions available for increased performance



	SR-150	SR-250
Material width (max)	150 mm	250 mm
Material thickness (max)	2.0 mm	20 mm
Feed roll width (std)	25 mm	50 mm
Feed roll width (max)	50 mm	150 mm
Indexes/min (max)	1500/min	1200/min



## CONTROL OPTIONS

### Nidec Kyori Mitsubishi Platform Press Control

- Proven and robust control
- 10.4" touch panel SVGA
- Fully integrated Vamco SR series feed control
- Speed meter
- Electronic 9-digit total counter and preset counter
- Die height adjustment meter
- Tool parameter storage
- Periodic maintenance announcements
- Fault history
- Automatic control of heater/chiller unit
- UL compliant

### Nidec Kyori Siemens Platform Basic Press Control

- Developed to meet needs for European customer, CE compliant
- Based off proven functionality of Mitsubishi platform
- 12.1" touch panel SVGA
- Fully integrated Vamco SR series feed control
- Speed meter
- Electronic 9-digit total counter and preset counter
- Die height adjustment meter
- Tool parameter storage
- Periodic maintenance announcements
- Fault history
- Automatic control of heater / chiller unit
- Separate control cabinet and operator console
- Interconnect of die controller and oiler signals
- i4.0 connectivity and remote maintenance

### NPA Siemens Platform European Press Control

- Newest, highest functioning press control to date
- Created specifically to place communication of specifications and customer support directly in Europe
- 15" touch IPC with ultra-high speed Ethernet communication
- Decentralized peripherals with Profinet
- Siemens integrated safety circuit \ with Profinet
- Fully integrated Vamco SR series feed control
- Total counter and (8) preset counters
- Integrated 8 channel digital die protection
- Integrated 4 channel press force monitoring
- Die height adjustment meter
- Periodic maintenance announcements
- Fault history
- Automatic control of heater / chiller unit
- Separate control cabinet and operator console
- Interconnect of die controller and oiler signals
- i4.0 connectivity and remote maintenance



## DIMENSIONS - VX-40

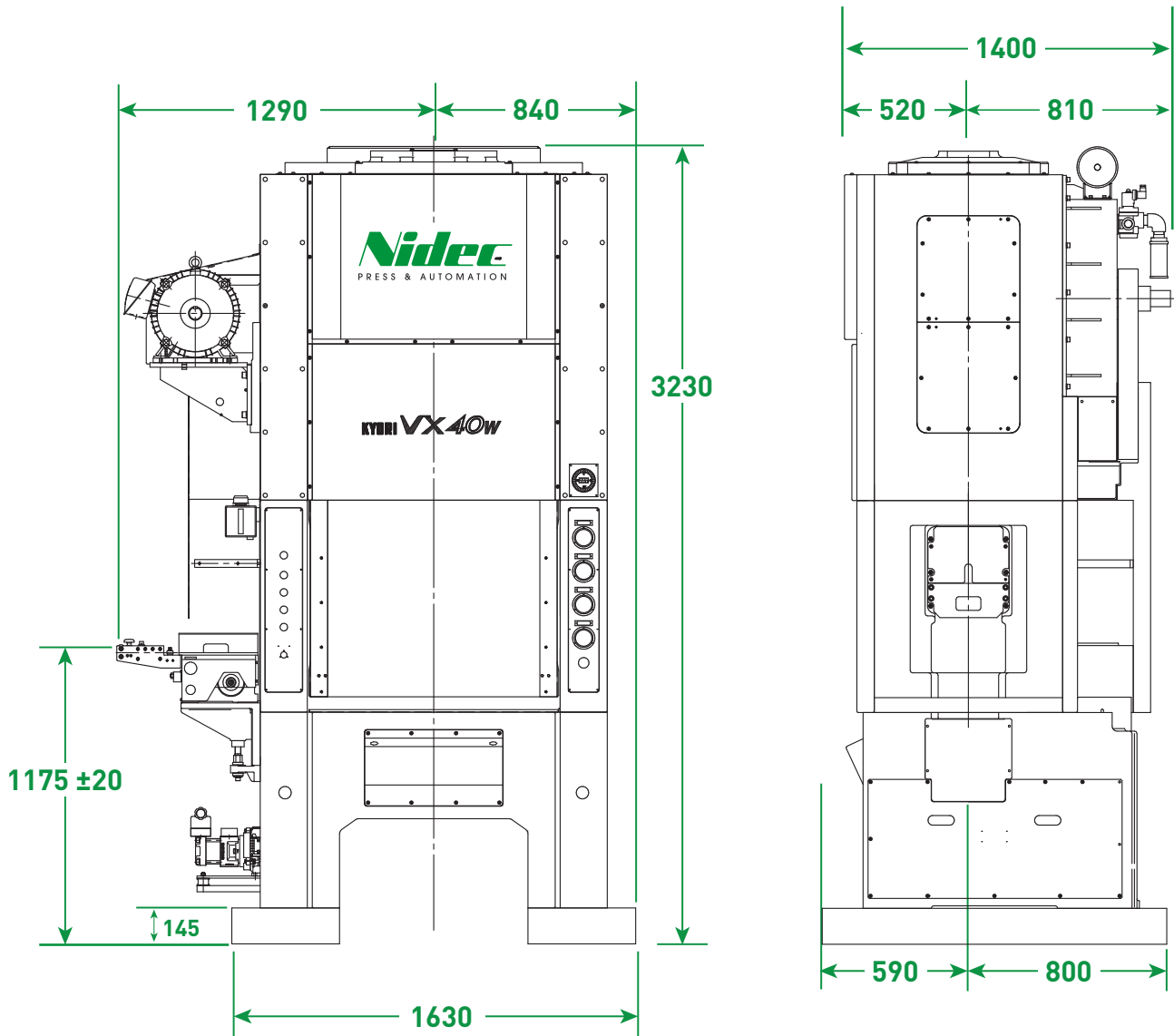

### VX-40 SLIDE

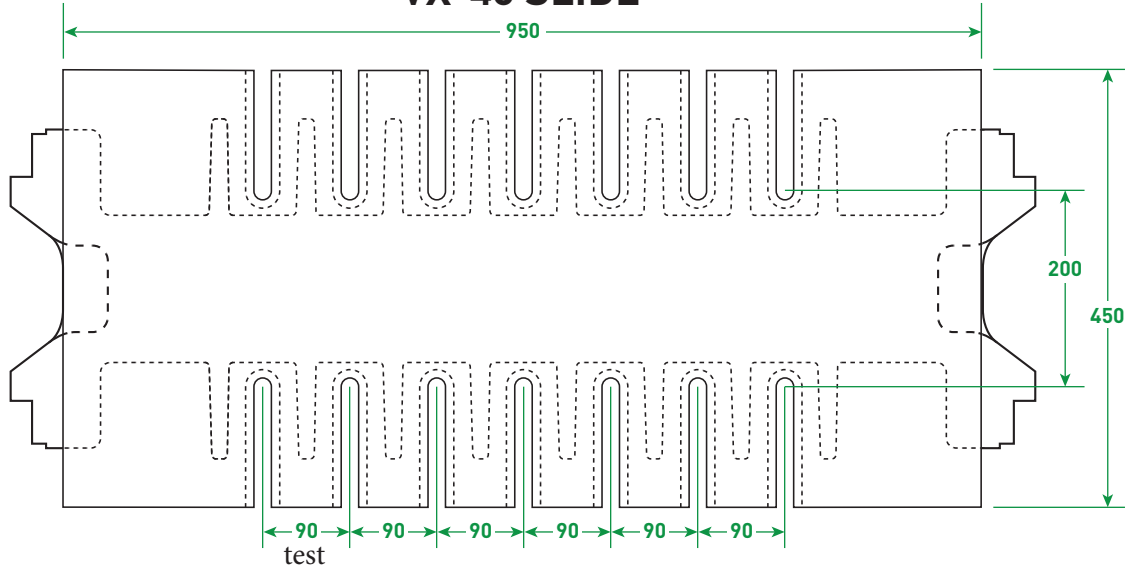

### VX-40 BOLSTER

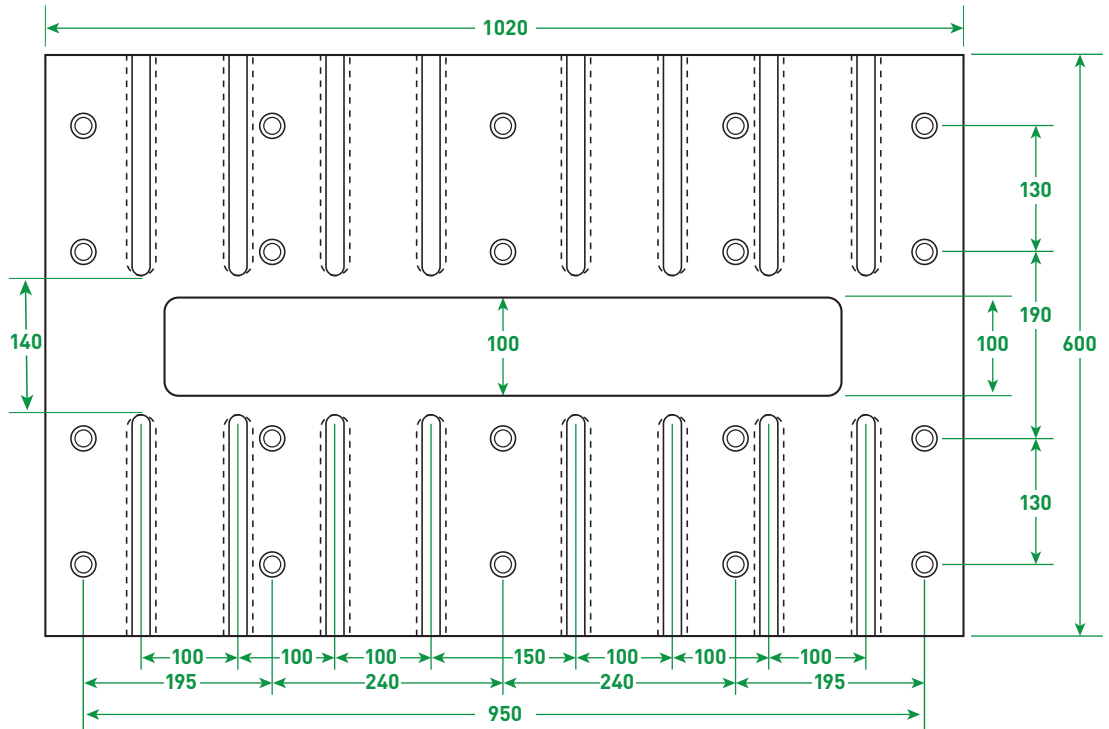

## DIMENSIONS - VX-50

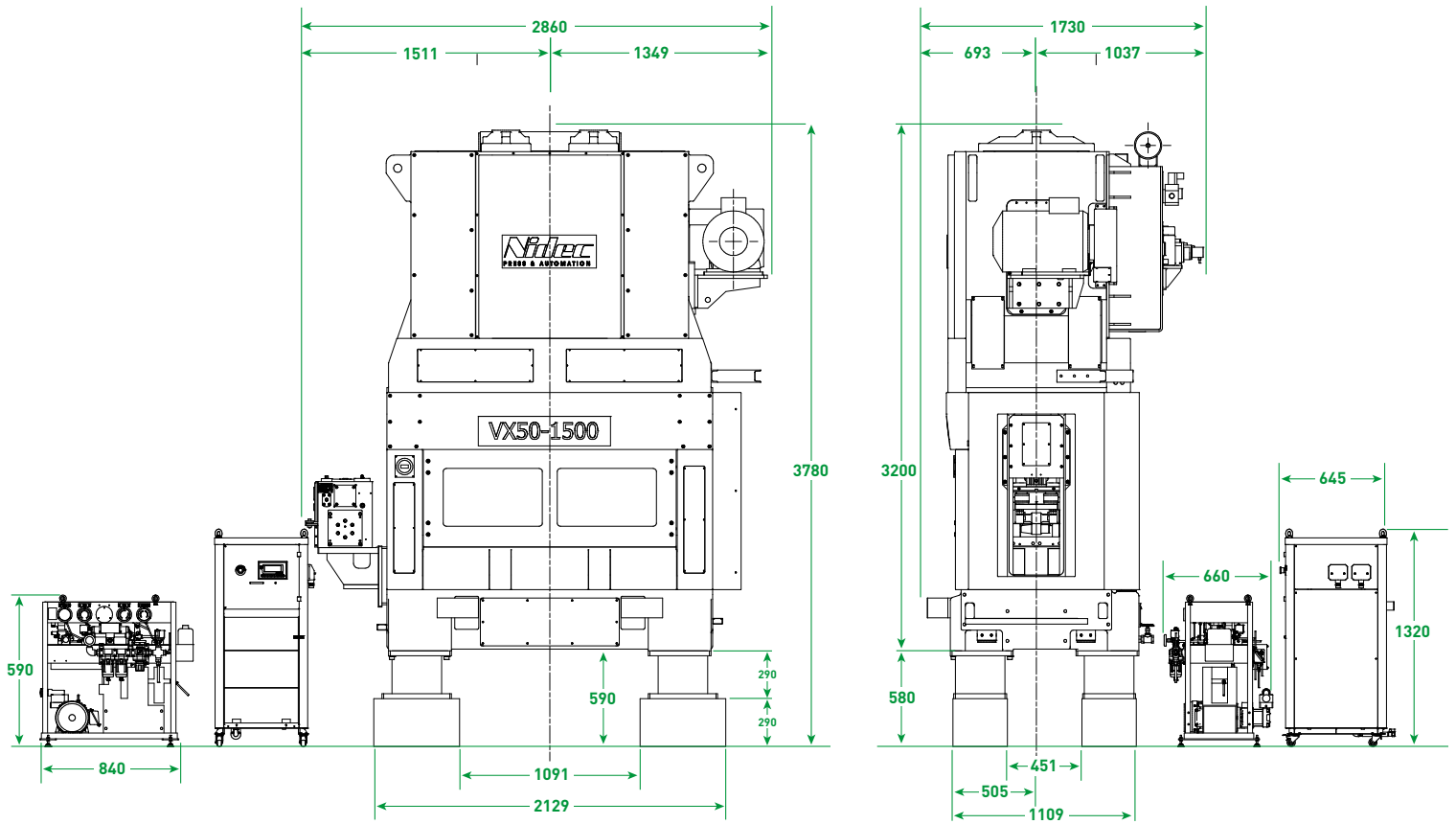

### VX-50 SLIDE

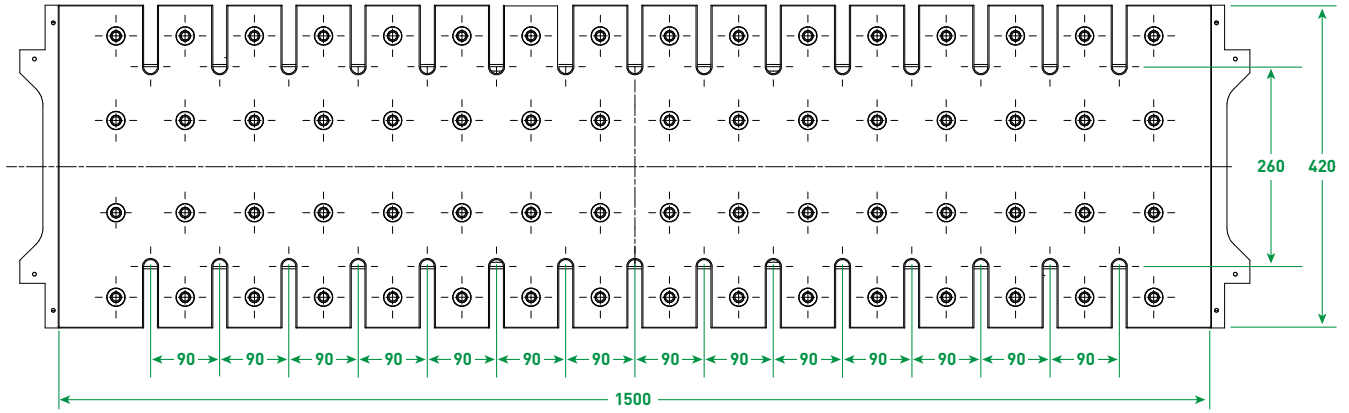

### VX-40 BOLSTER

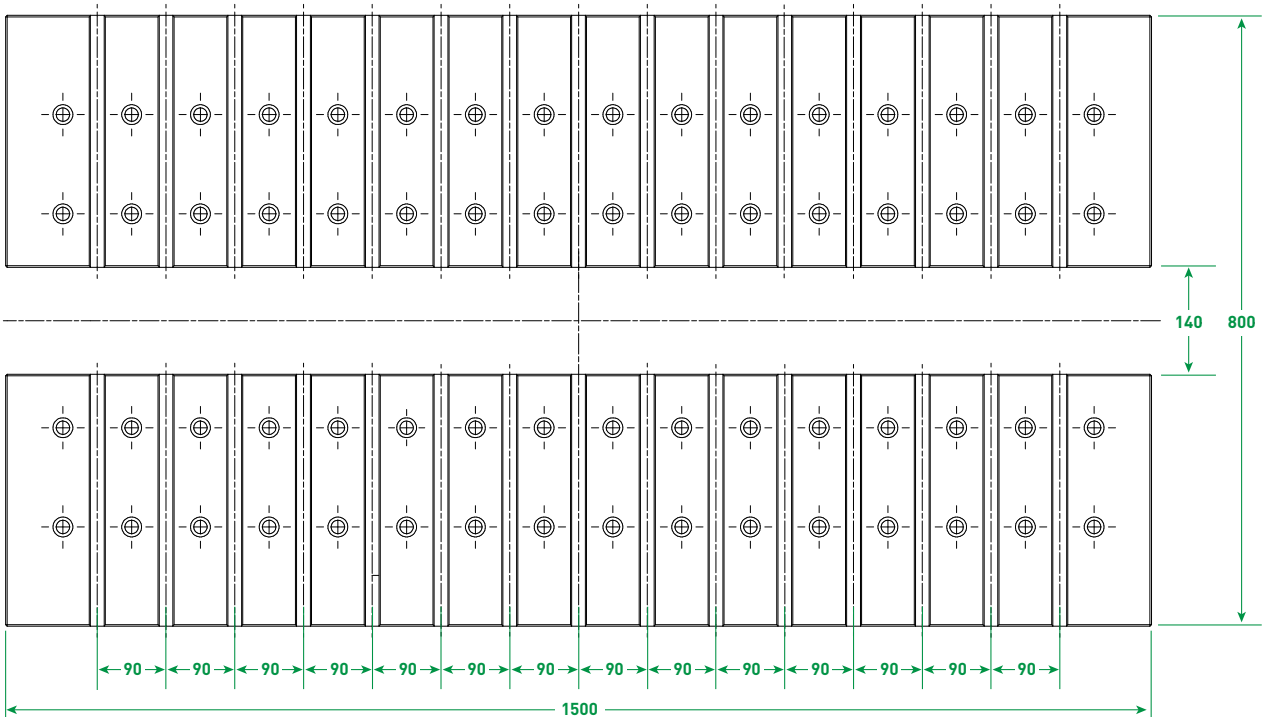

## DIMENSIONS - VX-80

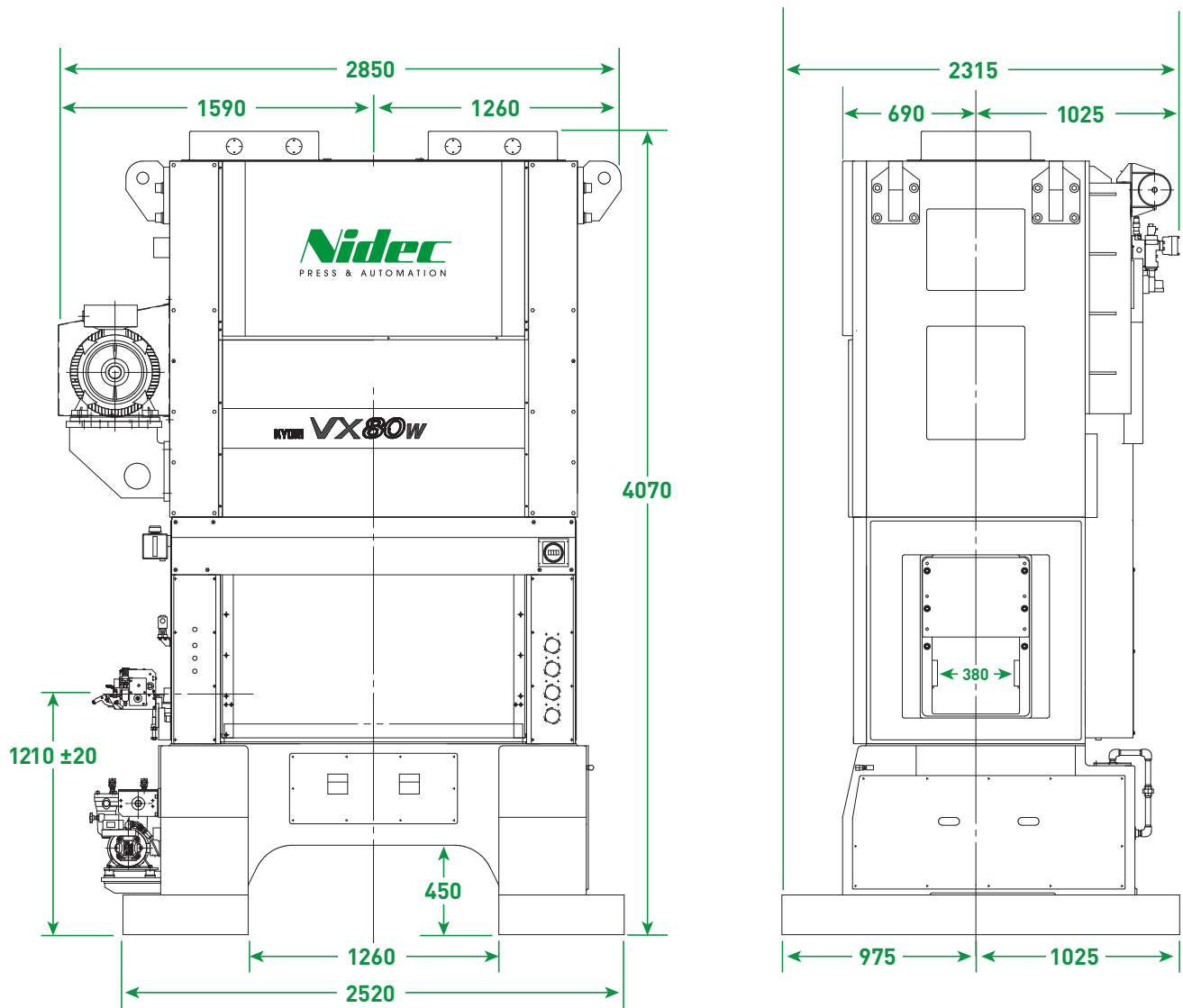

## VX-80 SLIDE

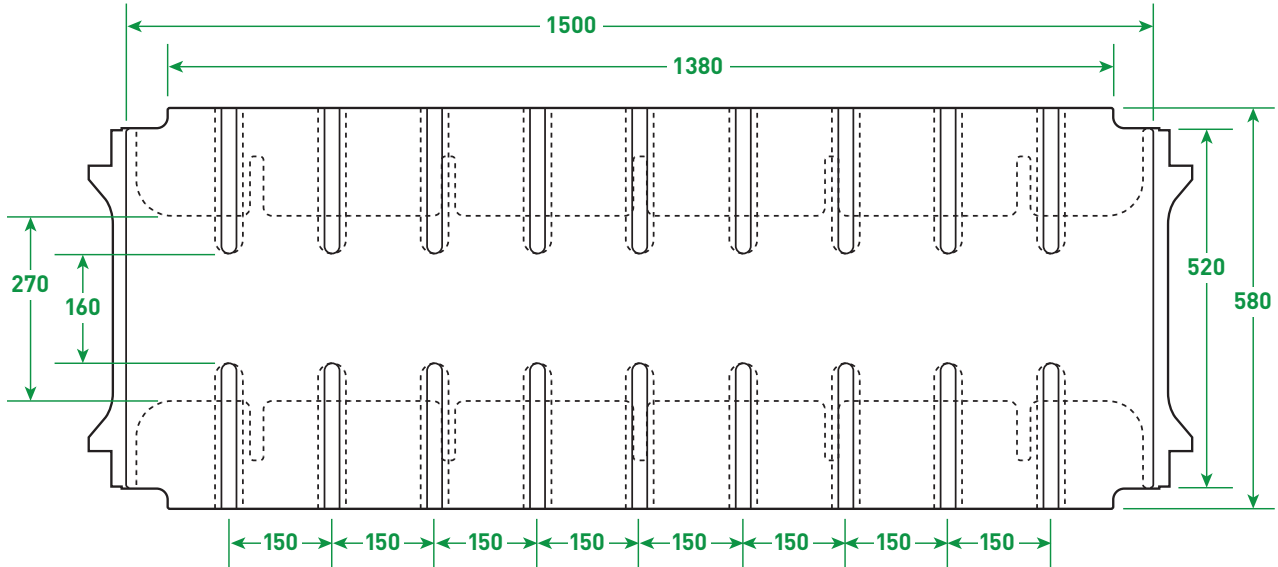

## VX-80 BOLSTER

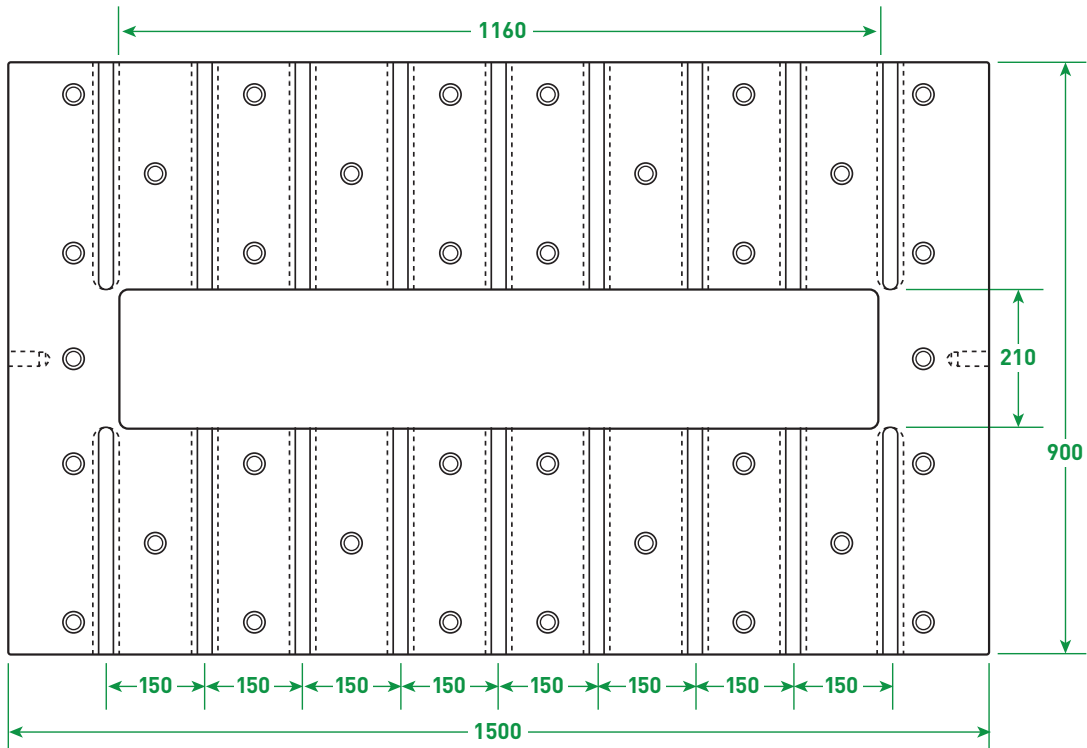

## SPECIFICATIONS

		VX-40W	VX-50-1500
Capacity	kN	400	500
Rating From Top of Bolster	mm	2,0	2,0
Stroke Length	mm	16/20/25/30/35/40/50	16/19/25/32/38/44/51/57/64
Strokes Per Minute	SPM	180~ 1000/800/600/500/400/350/260	100~ 1100/1000/880/780/700/600/ 500/450/400
Maximum Die Height	mm	300	350
Slide Adjustment	mm	50	55
Slide Area (R-L x F-B)	mm	950 x 450	1500 x 420
Bolster Area (R-L x F-B)	mm	950 x 600	1500 x 700
Bolster Thickness	mm	120	160
Bed Opening (R-L x F-B)	mm	760 x 120	1200 x 160
Bolster Opening (R-L x F-B)	mm	700 x 100	1140 x 140
Main Motor	kW	18,5	22
Upper Die Weight	kg	150	300



VX-80W	
	800
	2,0
	25/30/35/40/50/60/75
	120~ 650/550/470/400/330/270/150
	380
	80
	1380 x 580
	1500 x 900
	100
	1200 x 250
	1160 x 210
	37
	SL25~65mm:MAX550kg SL66~75mm:MAX450kg

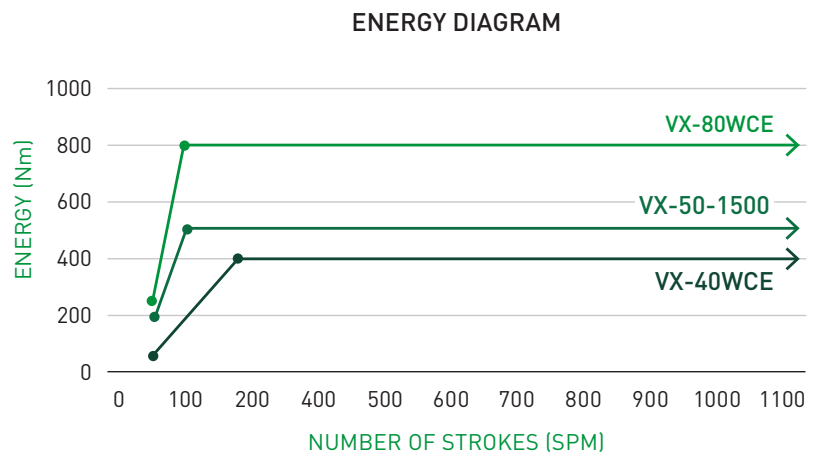
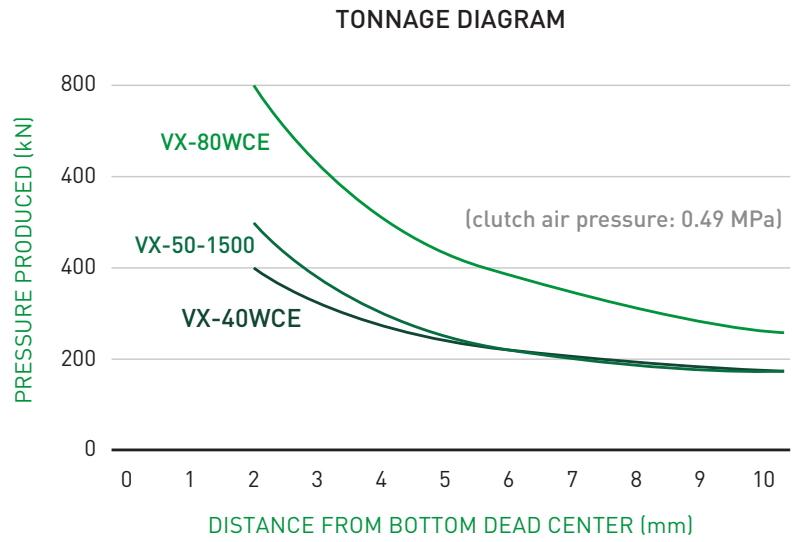



**One Brand: A World of Resources**

Nidec Press & Automation is the full service pressroom provider of choice for businesses in more than 90 countries and on six continents. Comprised of leading press room product brands, we ensure a complete offering of machinery, services and technology to meet your exact needs, enabling you to rely on one source.

Discover the freedom to achieve, to maximize and to drive your operation to exceed your goals. At Nidec Press & Automation, your success is the core of our focus and how we design our solutions to meet the rigid needs of the metal forming industry.

Choosing to work with us means you gain a constant resource with a global footprint, the brightest minds behind our solutions, and backed by regionally based OEM support ready to work as a natural extension of your team.

**Our promise to you is simple:  
We're with you whenever and wherever  
business takes you.**



**MACHINERY**

- Turn Key Systems
- Individual Components
- System/Tech Upgrades
- Industry 4.0 Software Upgrades
- Integrated Controls

**METAL FORMING PRESS APPLICATIONS**

- Mechanical
- Servo
- Transfer
- High-Speed & Electrical
- Electrical Vehicle (EV)
- Lamination
- Container Cupping
- Container End-Conversion
- Container Shell
- Gap/D-Frame

**AUTOMATION**

- Press Tending / Robotics
- Integrated Transfers
- High Speed Servo Feeds
- High Speed Gripper Feeds
- Heavy-Duty Coil Lines

**GLOBAL SERVICE NETWORK**

- Field Service
- Remanufacturing
- Spare Parts
- Technical Service
- Training
- Planned Maintenance
- Inspection & Audit
- Relocation
- Upgrade Services
- Engineering Services





## One Brand: A World of Resources

---

A single source solution that will help you find the efficiencies you want — all from the products, services and technology of Nidec Press & Automation.

[nidecpa.com](http://nidecpa.com)